

CUP SERIES

Amplifier



CUP800.2D
CUP1200.4D
CUP1600.4D
CUP1600.ID
CUP2000.ID
CUP3000.ID
CUP2500.5D

MANUAL

Introduction

Congratulations on your purchase of Cerwin-Vega Mobile products for your car audio system. You have chosen Cerwin Vega Mobile because you deserve the best!

Cerwin-Vega Mobile CVP series amplifiers are designed and engineered to reproduce extreme bass output in your vehicle! Our authorized Cerwin Vega Mobile dealers can help guide you with various installation applications and technical information in order to customize your sound system according to your own listening preferences. It is highly recommended that you have your new Amplifier installed by an authorized Cerwin Vega Mobile dealer to ensure that you receive the ultimate listening experience!

If you decide to install the amplifier by yourself, please thoroughly read through this manual before getting started. This manual will help familiarize yourself with this product and guide you through the installation process and procedures for this particular product. Please contact your local authorized Cerwin-Vega Mobile dealer if you have any further questions regarding the instructions in this manual pertaining to the amplifier application and installation process. If you require additional assistance, please contact the Cerwin Vega Mobile Technical Support Department during business hours at 213-261-4161.

MAKING IT LOUD SINCE 1954!



CVP800.2D

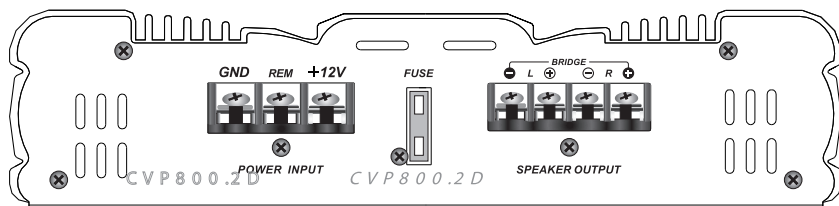
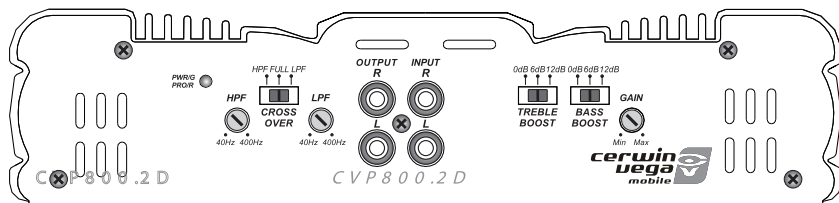

- ▶ LED Power and Protection Indicator
- ▶ HPF / LPF control
- ▶ Input Mode
- ▶ Input and Output Selected
- ▶ Treble Boost control
- ▶ Bass Boost control
- ▶ Gain control
- ▶ Power Input
- ▶ Fuse
- ▶ Speaker Output

CVP1200.4D / CVP1600.4D

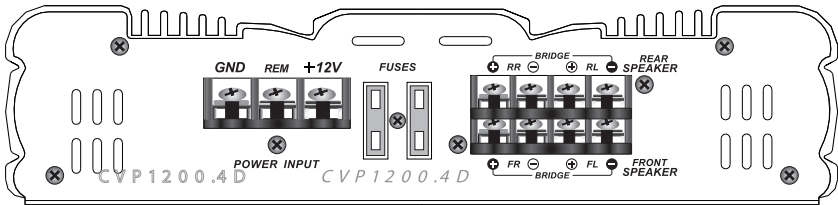
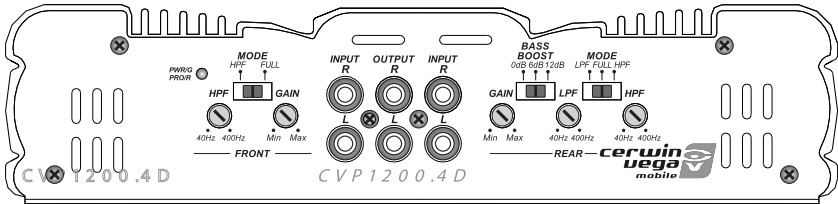

- ▶ LED Power and Protection Indicator
- ▶ HPF / LPF control
- ▶ Input Mode
- ▶ Input and Output Selected
- ▶ Bass Boost control
- ▶ Gain control
- ▶ Power Input
- ▶ Fuse
- ▶ Speaker Output

CVP1600.1D / CVP2000.1D / CVP3000.1D

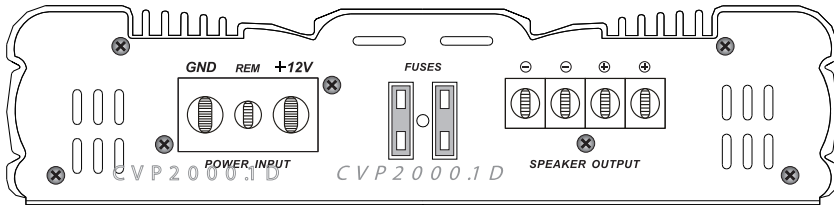
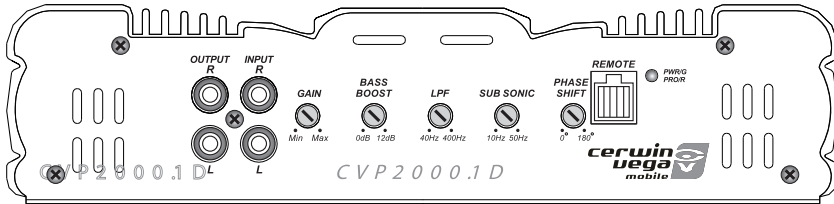

- ▶ Input and Output Selected
- ▶ Gain control
- ▶ Bass Boost control
- ▶ LPF control
- ▶ Sub Sonic control
- ▶ Phase Shift control
- ▶ Remote
- ▶ LED Power and Protection Indicator
- ▶ Power Input
- ▶ Fuse
- ▶ Speaker Output

CVP2500.5D

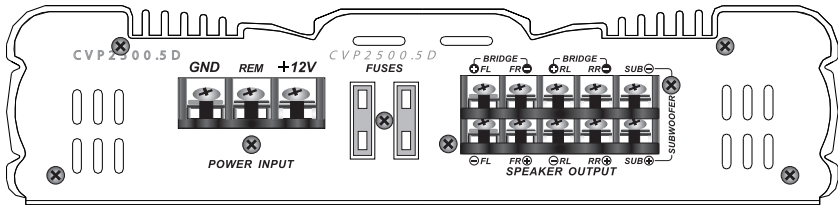
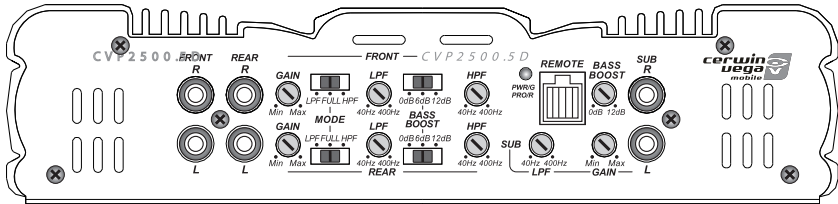

- ▶ LED Power and Protection Indicator
- ▶ HPF / LPF control
- ▶ Input Mode
- ▶ Front Rear and Sub Input Selected
- ▶ Bass Boost control
- ▶ Gain control
- ▶ Remote
- ▶ Power Input
- ▶ Fuse
- ▶ Speaker Output

System 1: 2-Channel Mode

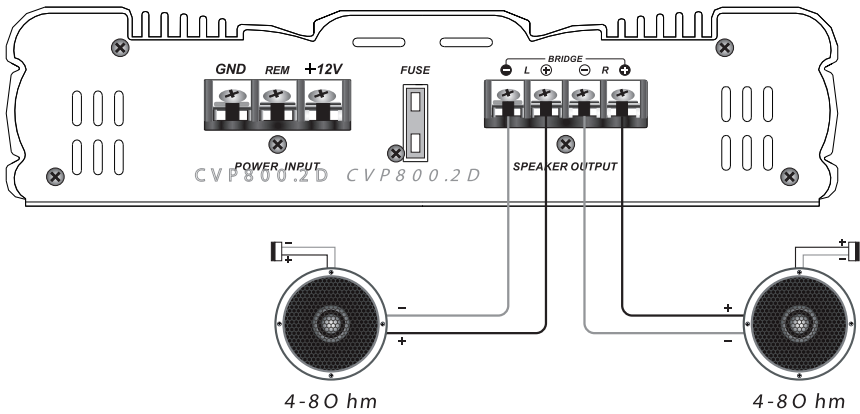
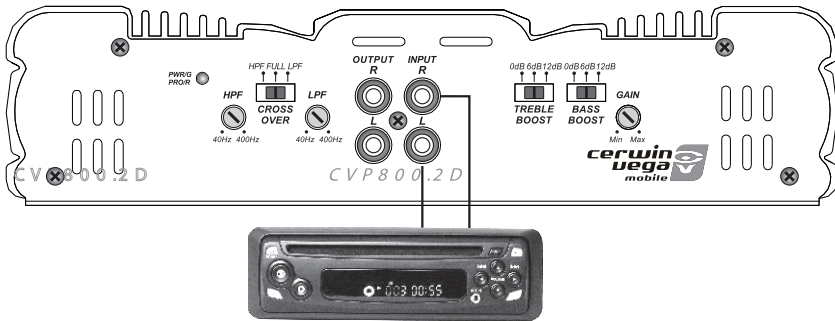

System 2: Subwoofer Connection

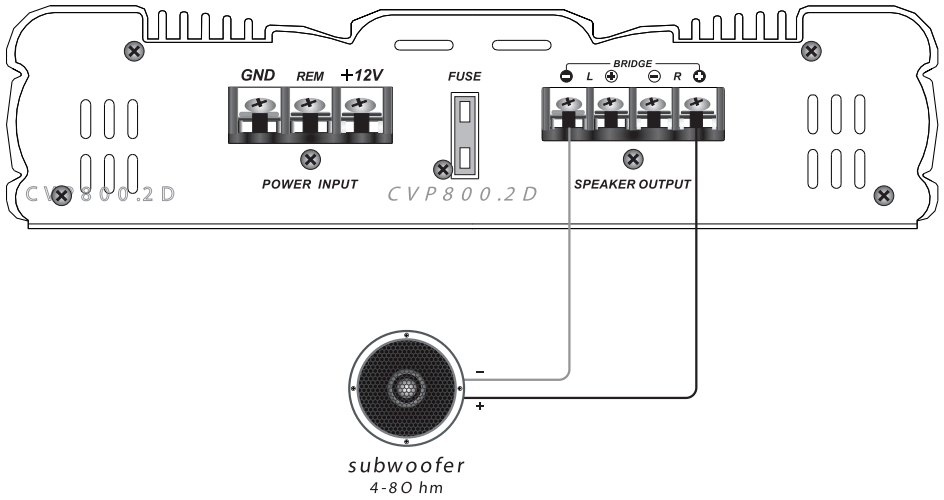

System 1: 4-Channel Mode

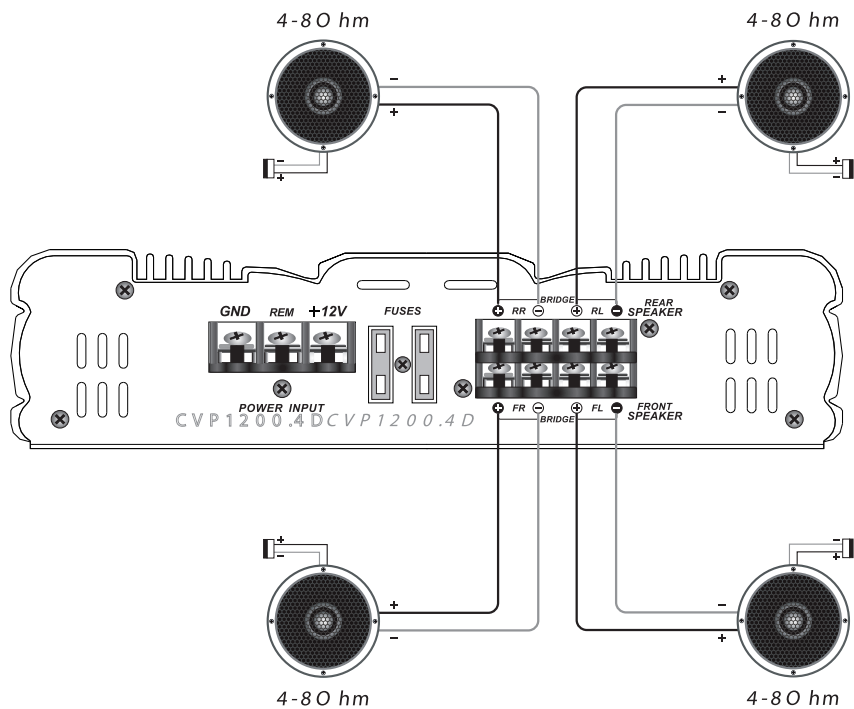
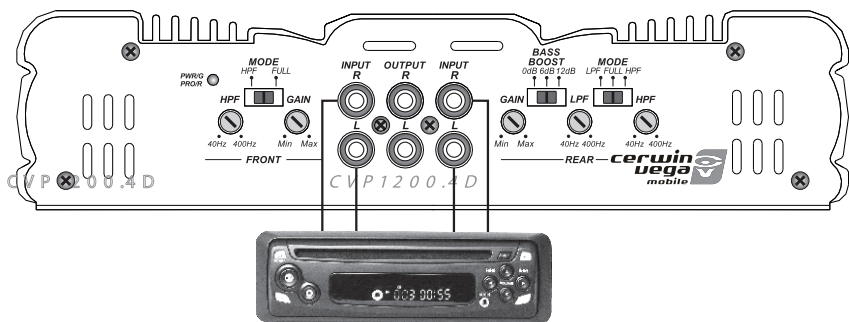

System 2: Subwoofer Connection

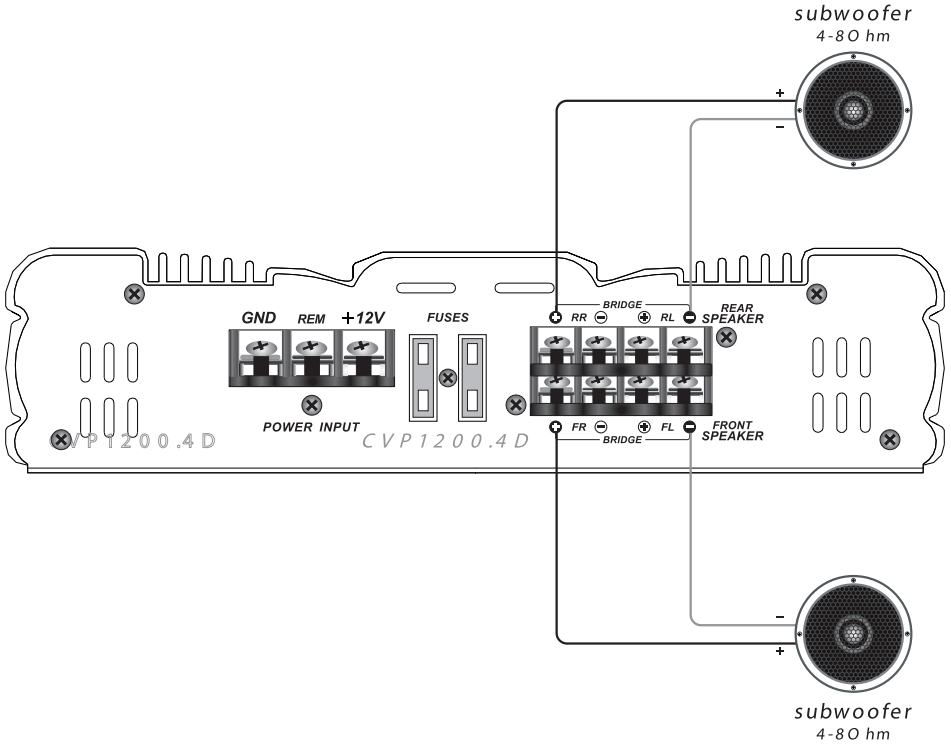

System 1: 4-Channel Mode

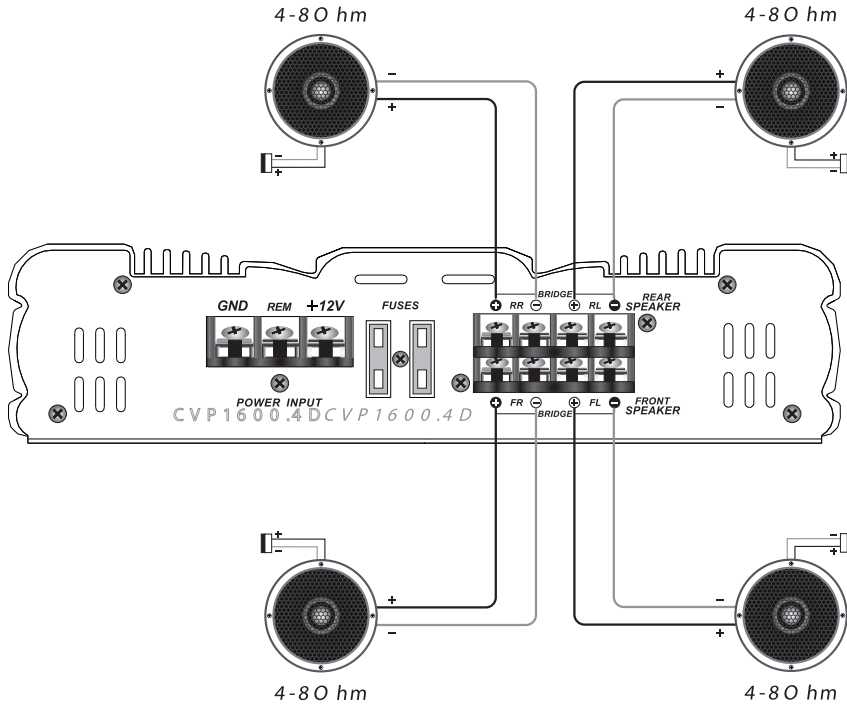
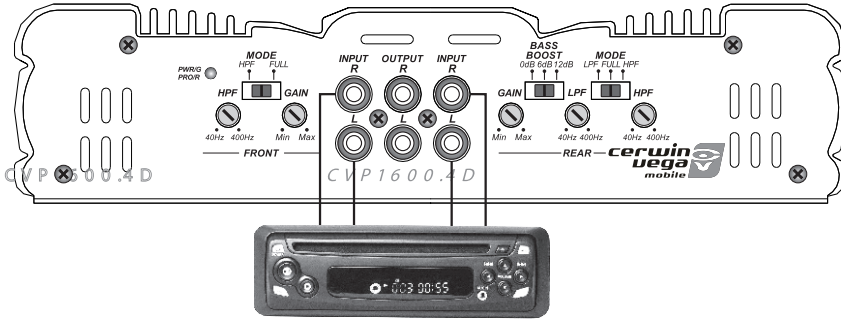

System 2: Subwoofer Connection

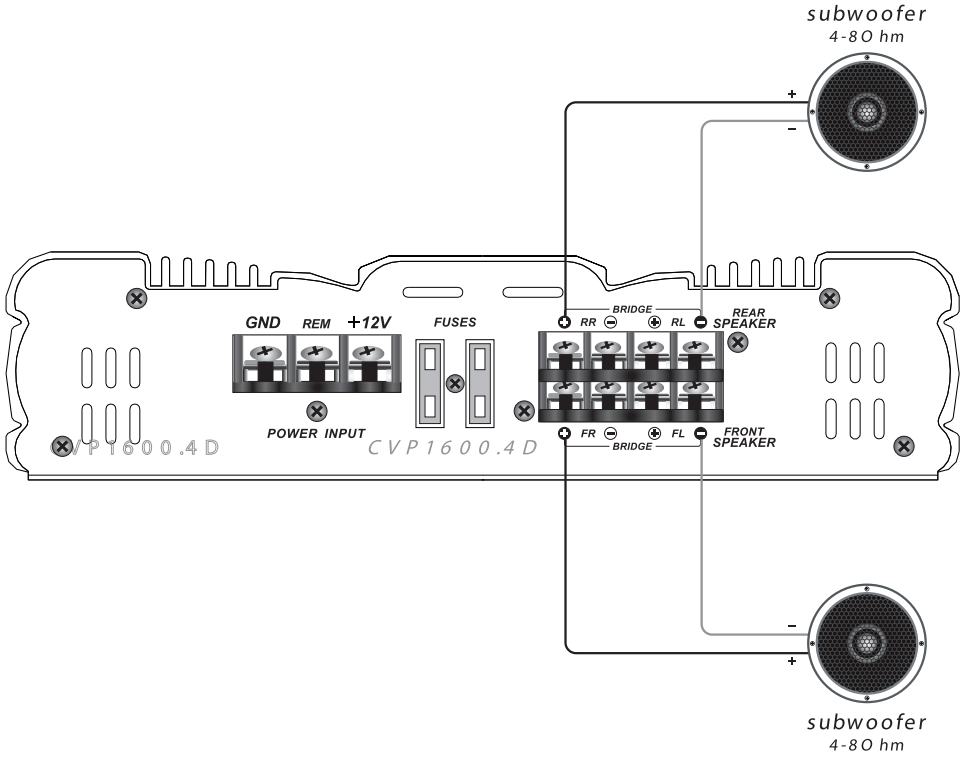

System 1: 1- Channel mode

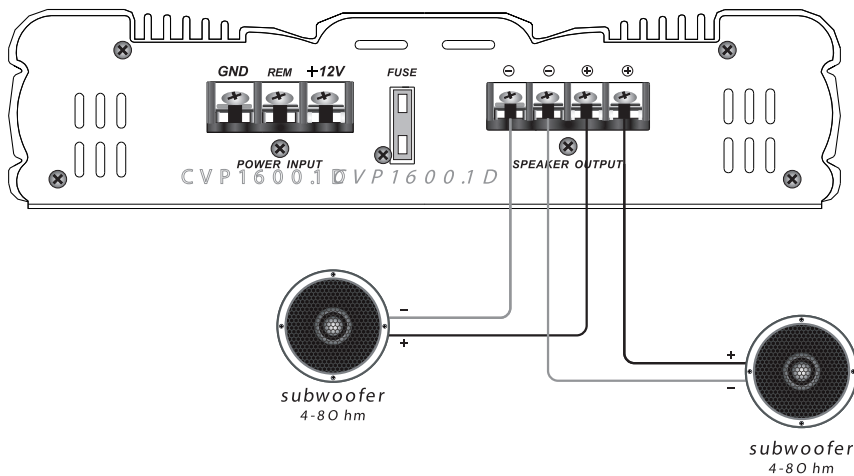
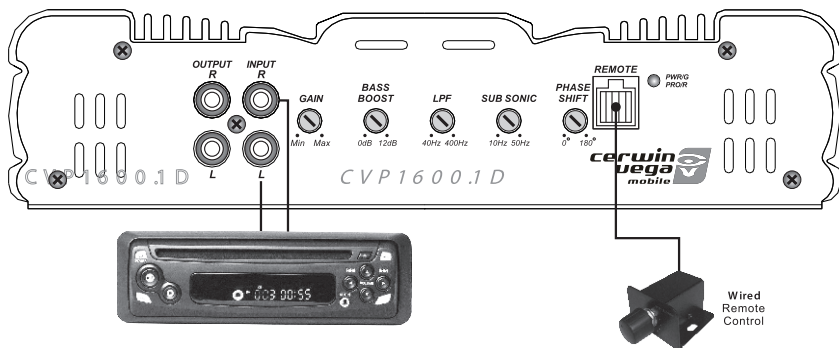

System 2: Subwoofer Connection

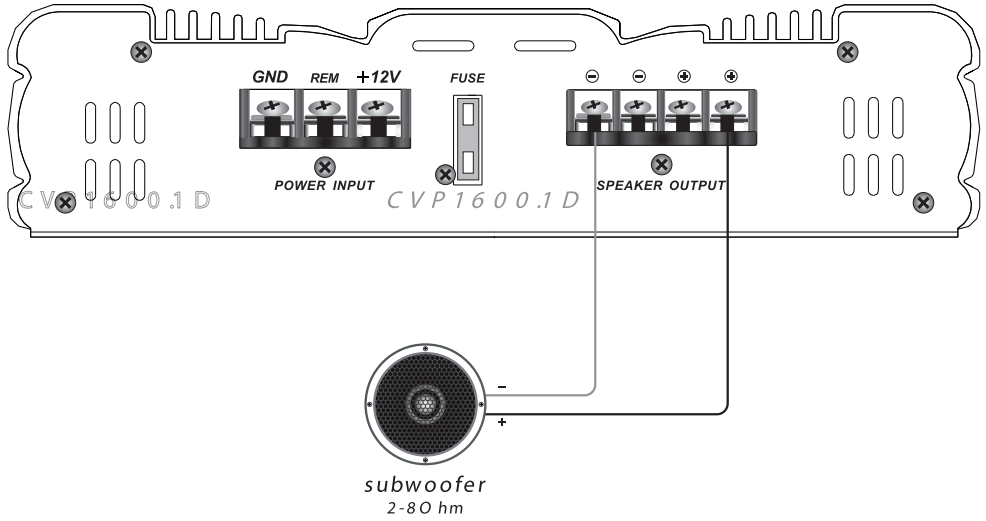

System 1: 1- Channel mode

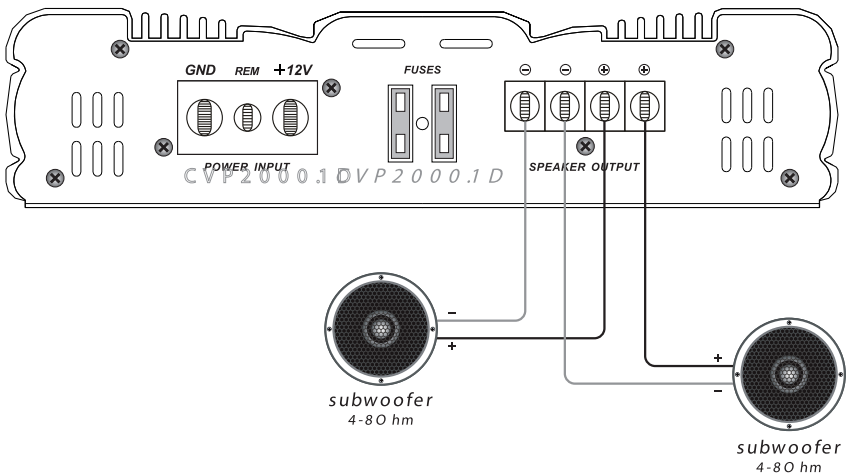
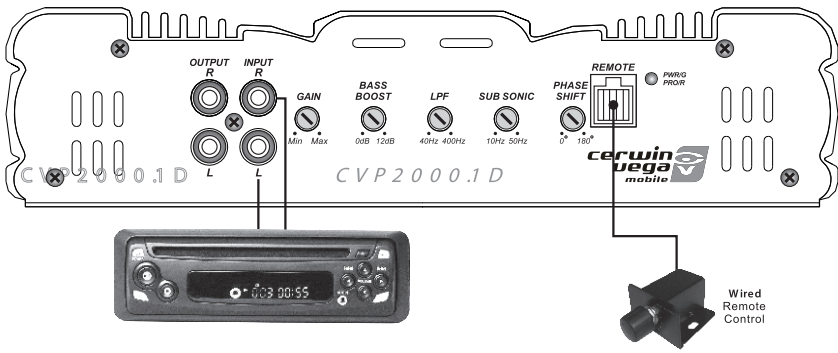

System 2: Subwoofer Connection

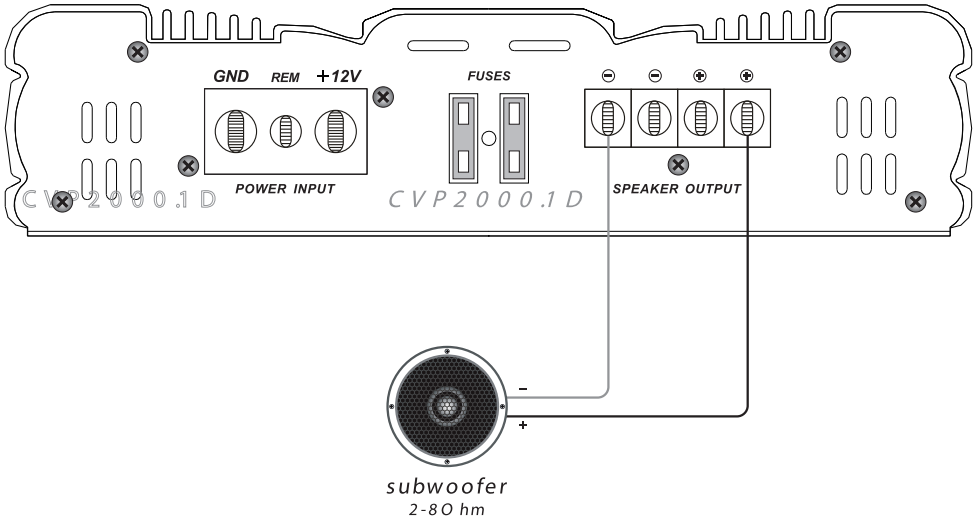

System 1: 1- Channel mode

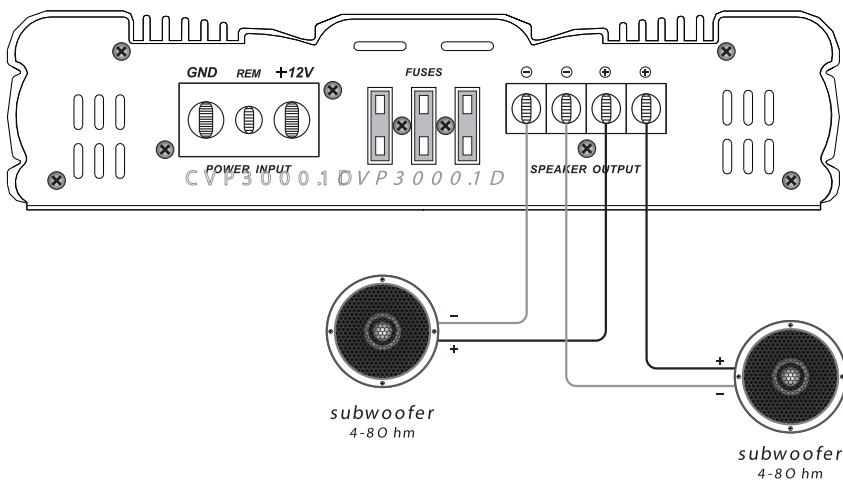
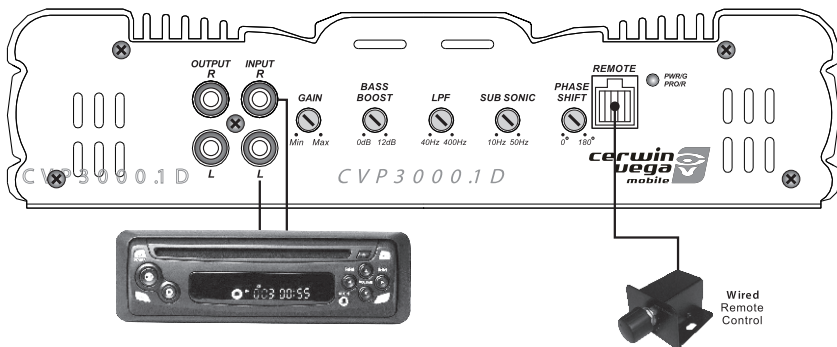

System 2: Subwoofer Connection

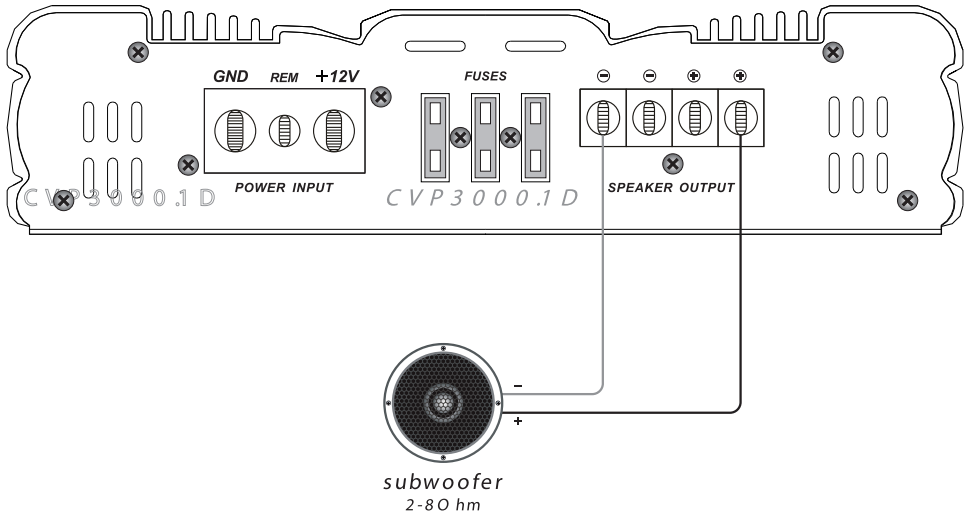

System 1: 5-Channel Mode

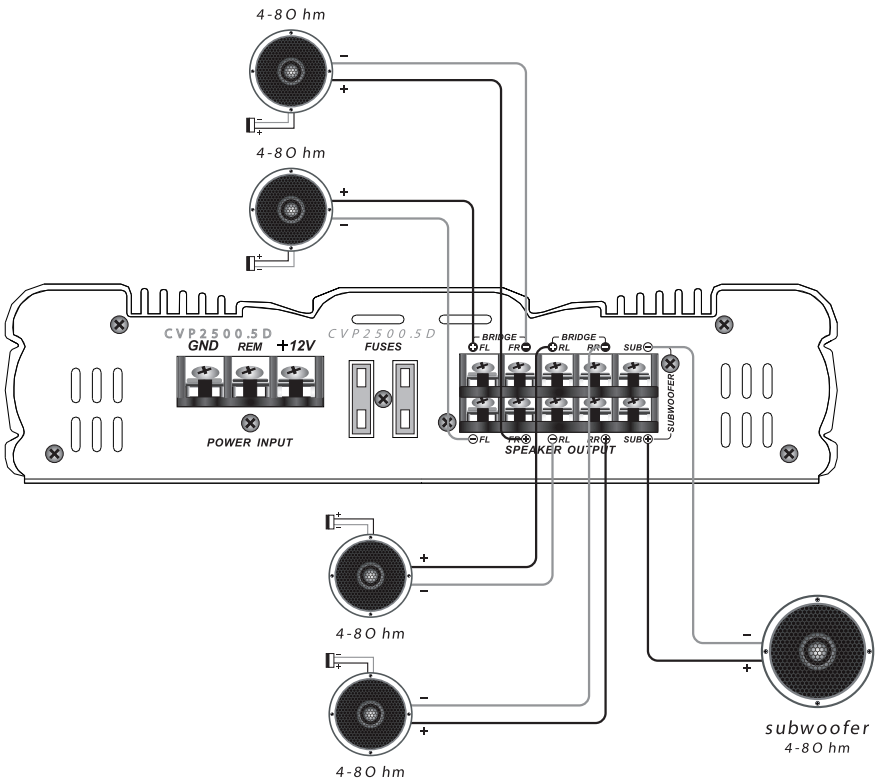
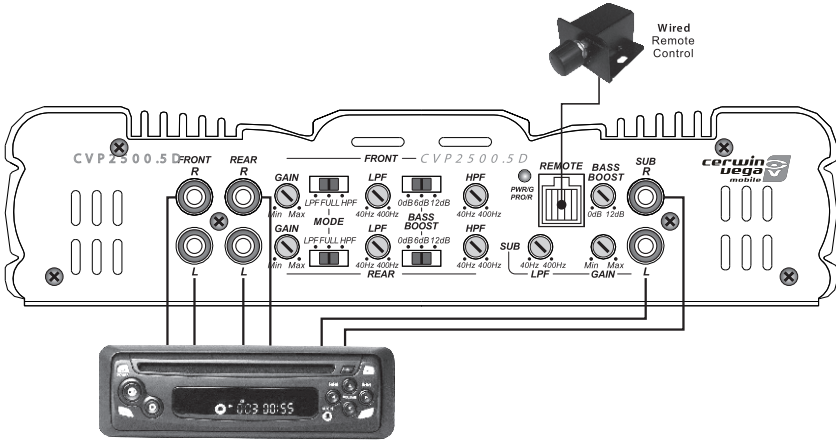

System 2: Subwoofer Connection

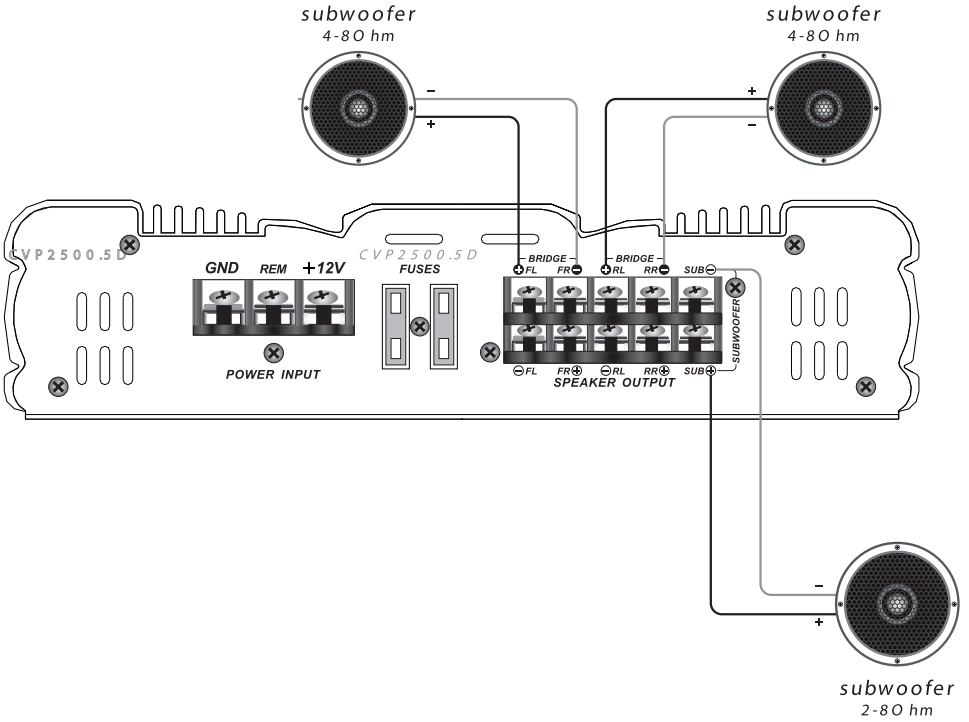

Troubleshooting

Problem	Possible Cause	Solution
No Output	Low or no remote turn-on input	Check remote turn-on voltage output on amplifier and correct as needed
	Fuse down	Check power wire integrity and reverse polarity; repair as needed and replace fuse
	Power wires not connected	Check power wire connections and repair/replace as needed
	Audio input not connected or no output from source	Check input connections and signal integrity; repair/replace as needed
	Speaker wires not connected	Check speaker wires and repair/replace as needed
Audio cycles on and off	Speakers are blown	Check system with known working speaker and repair/replace speakers as needed
	Thermal protection engages when amplifier heat sink temperature exceeds 90°C	Make sure there is proper ventilation for amplifier and improve ventilation as needed
	Loose or poor audio input	Check input connections and repair/replace as needed
Distorted output	Amplifier level sensitivity set too high, exceeding maximum output capability of amplifier	Reset gain. Refer to the turning section of the manual for detailed instructions
	Impedance load to amplifier too low	Check speaker impedance load. If below 20 stereo or 411 mono, rewire speakers to achieve a higher impedance
	Shorted speaker wires	Check speaker wire connections and repair/replace as needed
	Speaker incorrectly connected to amplifier properly	Check speaker wiring and repair/replace as needed. Refer to the installation section of this manual for detailed instructions
	Speakers are blown	Check system with known working speaker and repair/replace as needed

Problem	Possible Cause	Solution
Poor Bass Response	Speaker polarity may be reversed or wired incorrectly, causing cancellation at low frequencies.	Check speaker polarity and repair as needed.
	Crossover set incorrectly	Reset crossover. For detailed instructions, refer to the multi-cross crossover configuration section of this manual
Battery Fuse Blowing	Impedance load to amplifier is too low	Check speaker impedance load. If below 2Ω stereo or 4Ω mono, rewire speakers to achieve a higher impedance
	Short in power wire or incorrect power connection or wire	Check power and ground connections and repair as needed
	Fuse used is smaller than recommended	Replace with proper fuse size
		Check speaker impedance load. If below 2Ω stereo or 4Ω mono, rewire speakers to achieve a higher impedance and replace with recommended fuse size
Amplifier Fuse Blowing	Too much current being drawn	Check speaker impedance load. If below 2Ω stereo or 4Ω mono, rewire speakers to achieve a higher impedance and replace with recommended fuse size
		Check power and ground connections. Repair as needed
	Fuse used is smaller than recommended	Replace with proper fuse size

PRODUCT SPECIFICATIONS

	CVP800.2D	CVP1200.4D	CVP1600.4D	CVP1600.1D
RMS Power Rating (rated at 0.1% THD)				
RMS Power (2 Ω)	85Wx2	75Wx4	90Wx4	200Wx1
RMS Power (4 Ω)	60Wx2	55Wx4	70Wx4	120Wx1
Bridged (mono 1 Ω)	N/A	N/A	N/A	N/A
Bridged (mono 2 Ω)	N/A	N/A	N/A	N/A
Bridged (mono 4 Ω)	180Wx1	160Wx2	190Wx2	N/A
Type				
Topology	Class AB	Class AB	Class AB	Class AB
Power Supply				
Power Supply	Full PWM	Full PWM	Full PWM	Full PWM
Power Supply (Threshold)	10.0VDC - 16.0VDC	10.0VDC - 16.0VDC	10.0VDC - 16.0VDC	10.0VDC - 16.0VDC
Idle Current	(0.5A)	(0.7A)	(0.8A)	(0.5A)
Distortion				
THD (1KHz @4Ω)	<1%	<1%	<1%	<1%
S/N Ratio (A weighted @1W)	>90dB	>90dB	>90dB	>90dB
S/N Ratio (A weighted @ FP)	N/A	>105dB	>105dB	>105dB
Input Sensitivity				
Hi/Low Input Level	200mV-6V	200mV-6V	200mV-6V	200mV-6V
Input Impedance				
Low Input Level	20KΩ	20KΩ	20KΩ	20KΩ
Output Stage				
Output Impedance	2/4Ω	2/4Ω	2/4Ω	2/4Ω
Damping Factor	100	100	100	100
Bandwidth (-3dB)	10Hz-32KHz	10Hz-32KHz	10Hz-32KHz	10Hz-400Hz
Crossover (-12dB/Oct)				
Variable High-Pass	40Hz-400Hz	40Hz-400Hz	40Hz-400Hz	N/A
Variable Low-Pass	40Hz-400Hz	40Hz-400Hz	40Hz-400Hz	40Hz-400Hz
Variable Sub-Sonic	N/A	N/A	N/A	10Hz-50Hz
Fuse Ratings				
ATC/MAXI FUSE	30Ax1	25Ax2	30Ax2	35Ax1
Dimensions:				
Length (inches)	7.88"x9.38"x2.25"	11.03"x9.38"x2.25"	11.82"x9.38"x2.25"	8.67"x9.38"x2.25"
Length (mm)	200x238x57mm	280 x 238 x 57mm	300x238x57mm	220x238x57mm

PRODUCT SPECIFICATIONS

	CVP2000.1D	CVP3000.1D	CVP2500.5D
RMS Power Rating (rated at 0.1% THD)			
RMS Power (2 Ω)	400Wx1	600Wx1	85Wx4 + 300Wx1
RMS Power (4 Ω)	250Wx1	370Wx1	65Wx4 + 185Wx1
Bridged (mono 1 Ω)	N/A	N/A	N/A
Bridged (mono 2 Ω)	N/A	N/A	N/A
Bridged (mono 4 Ω)	N/A	N/A	180Wx2 +NA
Type			
Topology	Class AB	Class AB	Class AB
Power Supply			
Power Supply	Full PWM	Full PWM	Full PWM
Power Supply (Threshold)	10.0VDC -	10.0VDC -	10.0VDC -
Idle Current	16.0VDC (0.7A)	16.0VDC (0.8A)	16.0VDC (1.0A)
Distortion			
THD (1KHz @4Ω)	<1%	<1%	<1%
S/N Ratio (A weighted @1W)	>90dB	>90dB	>90dB
S/N Ratio (A weighted @ FP)	>105dB	>105dB	>105dB
Input Sensitivity			
Hi/Low Input Level	200mV-6V	200mV-6V	200mV-6V
Input Impedance			
Low Input Level	20KΩ	20KΩ	20KΩ
Output Stage			
Output Impedance	2/4Ω	2/4Ω	2/4Ω
Damping Factor	100	100	100
Bandwidth (-3dB)	10Hz-400Hz	10Hz-32KHz	10Hz-32KHz / 10Hz-400Hz
Crossover (-12dB/Oct)			
Variable High-Pass	N/A	N/A	40Hz-400Hz
Variable Low-Pass	40Hz-400Hz	40Hz-400Hz	40Hz-400Hz
Variable Sub-Sonic	10Hz-50Hz	10Hz-50Hz	N/A
Fuse Ratings			
ATC/MAXI FUSE	30Ax2	30Ax3	40Ax2
Dimensions:			
Length (inches)	13.4"x9.38"x2.25"	15.76"x9.38"x2.25"	14.97"x9.38"x2.25"
Length (mm)	340x238x57mm	400x238x57mm	380x238x57mm

Warranty

Thank you for purchasing a Cerwin Vega Mobile product and we hope to provide you with countless hours of listening enjoyment. Please take a brief moment to register your new product. By registering your new product, you will receive benefits such as:

- Important product notifications that may pertain to your purchase.
- Confirmation and record of ownership in case of loss or theft.
- Knowledgeable customer service and technical assistance pertaining to your product.

To register your new product, please visit our website at:
www.cerwinvegamobile.com

Registration is voluntary and failure to register will not diminish your limited warranty rights.

Limited Warranty (U.S.A.)

Cerwin Vega Mobile warrants all of our amplifiers and speakers to be free of defects in materials and workmanship for a period of one (1) year.

This warranty is non-transferable and applies only to the original purchaser from an authorized Cerwin Vega Mobile dealer. If service is required and necessary under this warranty due to manufacturing defect or malfunction, then Cerwin Vega Mobile will repair and/or replace defective product with either new or remanufactured like product at no charge at our discretion.

Damage to product caused by the following will not be covered under this warranty: abuse, accident, misuse, neglect, modifications, repairing attempts, seller/installer misrepresentation.

This warranty does not cover any incidental, consequential, or cosmetic damage due to accidents or normal wear and tear, nor does it cover the cost of removing or reinstallation of the product.

Warranty is void if the product's serial number has been removed, defaced, and/or tampered with.

Warranty Procedure:

We recommend that you contact your Cerwin Vega Mobile authorized dealer where your original purchase was made to initiate all warranty claims. Our authorized dealers can guide you through the warranty procedure to ensure that your claim will be processed in a timely manner. All warranty returns must be accompanied with a proof of purchase (a copy of the original sales receipt) and be shipped freight prepaid to our facility with an RA (Return Authorization) number clearly marked on the outside of the package. Direct returns from consumers or non-authorized dealers will be refused if shipped without a valid RA number authorized by Cerwin Vega Mobile beforehand.

For subwoofer returns, remove the cone from the basket by cutting the surround and then the spider, thus allowing the cone to completely lift out. All returns must have the serial numbers taped to the cone. The serial number can be found on the basket of all speakers and underneath the spider attached to the top of the magnet plate. Please remove the sticker and tape it to the cone.

For coaxial speaker returns, the tweeter should be broken off and sent in with the cone. For component speakers, only return the defective part such as tweeter, midbass, or crossover only.

Products purchased in countries outside the U.S.A. are warranted by the CVM authorized country distributor in which the product was purchased, go to www.cerwinvegamobile.com to find contact information for warranty within your country.

Please Ship All Warranty Claims With Pre-Authorized RA Number To:

CV&DA Holdings, Inc.
ATTN: Customer Service Department
3761 South Hill St.
Los Angeles, CA 90007 USA

Please Contact Customer Service for Further Warranty Information:

U.S.A.
Tel: 213-261-4161 Hours: 8:30 AM – 5:30 PM (Pacific Standard Time)

INTERNATIONAL

Products purchased outside of the U.S.A. are covered only by that country's distributor and not by Cerwin Vega Mobile U.S.A.



**3761 South Hill Street
Los Angeles 90007, USA
P 213-261-4161 / F 213-947-4767**

WWW.CERWINVEGAMOBILE.COM

**© 2021 Cerwin Vega Mobile All rights reserved.
(a division of CV & DA Holdings, Inc.)**