

**IN-DASH INSTALLATION KIT FOR
2001-04 MERCEDES-BENZ C-CLASS
AND C230 COUPE VEHICLES**

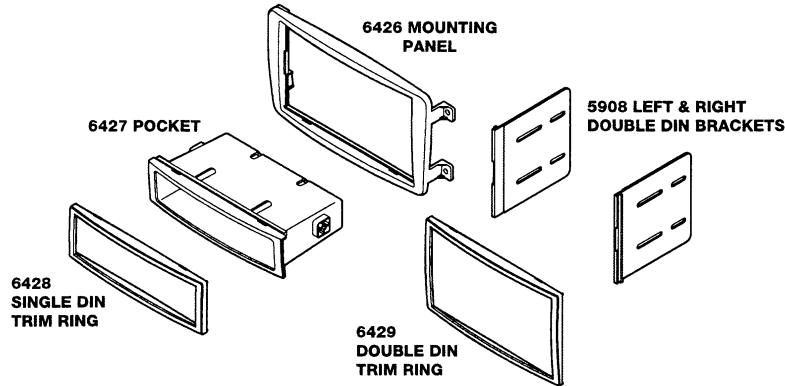

INTRODUCTION / PRELIMINARY

This premium installation kit is for 2001-04 Mercedes-Benz C-Class & C230 Coupe vehicles. Included are all the parts you need to mount your car stereo or CD player into your vehicle's dash. Refer to the individual instruction in this manual to remove your vehicle's factory radio and assemble the kit.

CAUTION
DISCONNECT YOUR VEHICLE'S NEGATIVE BATTERY TERMINAL BEFORE THE INSTALLATION TO HELP PREVENT ELECTRICAL DAMAGE. WE RECOMMEND THE USE OF A VOLT/OHM METER OVER A TEST LIGHT TO CHECK WIRING. A TEST LIGHT OR GROUNDED WIRE PROBE CAN CAUSE DAMAGE TO THE VEHICLE'S COMPUTER AND/OR DIAGNOSTIC SYSTEMS. AVOID ALL FACTORY AIRBAG WIRING - AIRBAGS CAN ACCIDENTALLY DEPLOY CAUSING SERIOUS INJURY OR DEATH.

- NOTES**
- See your vehicle's instructions for any special tools your installation might require.
 - Read all instructions accompanying your car stereo for proper wiring and mounting instructions.

IMPORTANT!

Do Not Return Product to the Retailer!

IF YOU NEED ASSISTANCE OR REPLACEMENT PARTS

Call us FIRST at ...

1-800-621-3695 ext 3

Toll Free, No-Charge tech support

* FRIENDLY CUSTOMER SERVICE TECHNICIANS
* YOU WON'T BE ON HOLD LONGER THAN 5 MINUTES

OUR HOURS ARE:
Monday - Friday 8:00 a.m. to 5:30 p.m. (PST)
Saturday 8:00 a.m. to 2:00 p.m. (PST)

FACTORY WIRING CODES

For Factory Wiring Codes go to: www.scosche-cars.com

CAR STEREO CONNECTORS

PROVIDE EASY CONNECTION OF YOUR CAR STEREO TO FACTORY WIRING HARNESS.

VWO1B
1986-up select Volkswagen

VWA2B
VW antenna adapter

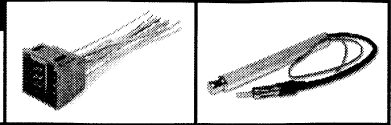

MOUNTING THE STEREO

ISO DIN MOUNT

1. Snap the 5908 left & right brackets to the 6426 kit panel.
2. Align the 6427 pocket to the lower edge of the panel. Secure the pocket to the left & right mounting brackets with the two (2) supplied screws in the installation kit.
3. Mount stereo to brackets with the stereo's supplied screws.

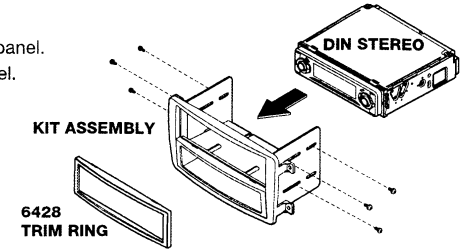

DOUBLE DIN MOUNT

1. Snap the 5908 left & right brackets to the 6426 kit panel.
2. Align, position and bolt the aftermarket double DIN-ISO head unit to the left & right mounting brackets. Use the hardware supplied with the aftermarket double DIN-ISO head unit to secure the mounting brackets to the aftermarket stereo.

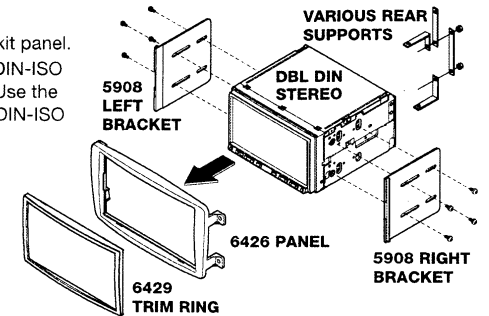

CAUTION:
REAR SUPPORT AVAILABLE SEPARATELY. REAR SUPPORTING THE STEREO ADDS TO THE INSTALLATION'S STRUCTURAL INTEGRITY.

STEREO REMOVAL

2001-04 C-CLASS

1. Unsnap the gear shifter trim (with gear indicators).
2. Unclip the console trim bezel and remove.
3. Remove the ashtray insert. Remove the ashtray assembly by releasing (2) plastic clips on the bottom lip of the assembly.
4. Unclip (2) metal clips along the bottom edge of the radio/climate control trim bezel and remove the bezel. Using a small screwdriver, push the lower clip inward and rotate the vent upward to expose (1) torx-head screw. Loosen the torx-head screw. (It is NOT necessary to remove the screw). Using a small screwdriver, push the upper clip inward and rotate the vent downward to expose (1) spring clip in the top corner. Push down on the spring clip, pull out on the vent assembly and remove. (Repeat steps for other vent).
5. Remove (2) Phillips screws securing the factory head unit and disconnect the wiring.

2002-04 C230 COUPE

1. Using small flathead screwdriver push lower clips in air vent inward and rotate vents up. Loosen (2) T20 Torx. (one on each side)
2. Using same screwdriver, push in upper clips and rotate vents downward to expose metal clips in top corners. Push clips down and pull down on vent bezel at the same time to remove.
3. Raise ashtray cover up halfway and release (2) metal clips (one in each corner). Pull out stereo bezel, disconnect and remove.
4. Extract (2) T20 Torx securing stereo. Disconnect and remove.

LIABILITY DISCLAIMER

This instruction booklet is based on carefully documented data and research of automobile dash disassembly, wire harness/codes and information pertaining to installation of this kit (MZ2340B) in 2001-04 Mercedes-Benz C-Class & C230 vehicles. Scosche Industries, Inc. can not be held responsible for discrepancies/inconsistencies that may occur due to the automobile manufacturing changes or options, or damage that may occur in the automobile during the installation of components while using this booklet.